

1" Rotogages® for Large Mobile and Stationary Containers

For Small Mobile or Stationary Containers
A9091R and A9092R Series

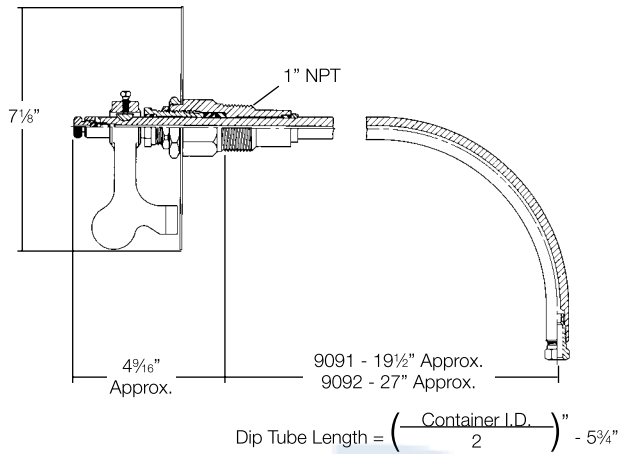

For Large Stationary Containers
9093RS, 9094RS and 9095RS Series

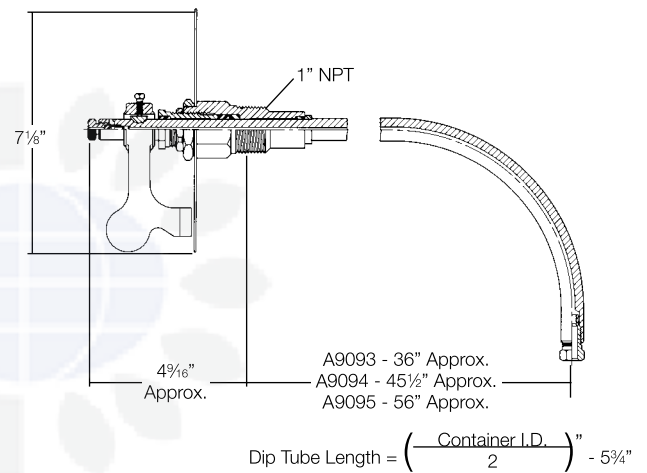

For Large Mobile or Stationary Containers
A9093TS, A9094TS and A9095TS Series

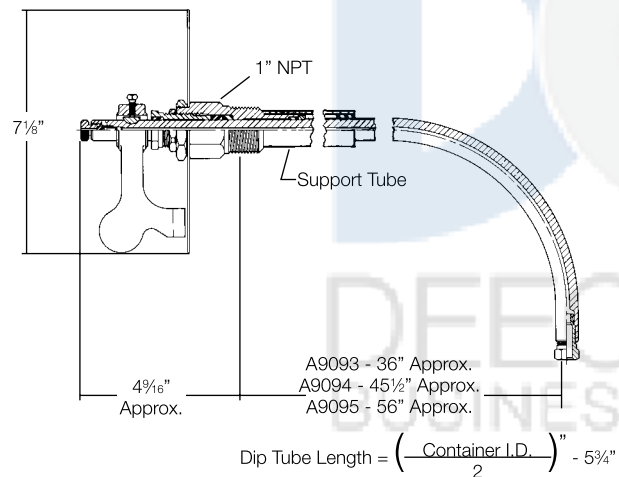

Ordering Information

Part Number		For Container Inside Diameter			
		Ellipsoidal Heads		Hemispherical Heads	
		Side Mounted	End Mounted	Side Mounted	End Mounted
For Mobile or Stationary Containers	For Stationary Containers Only				
A9091R	-	30" - 45"	30" - 75"	30" - 45"	30" - 45"
A9092R	-	46" - 61"	76" - 108"	46" - 61"	46" - 61"
A9093TS*	A9093RS	62" - 79"	109" - 147"	62" - 79"	62" - 79"
A9094TS*	A9094RS	80" - 99"	-	80" - 99"	80" - 99"
A9095TS*	A9095RS	100" - 147"	-	100" - 147"	100" - 147"

* Supported Design

NOTE: The dip tube must be cut to the required length (1/2" of container inside diameter minus 5 3/4").