

High Pressure Industrial / Commercial Pounds-to-Pounds Regulators

1580M Series and AA1580M Series

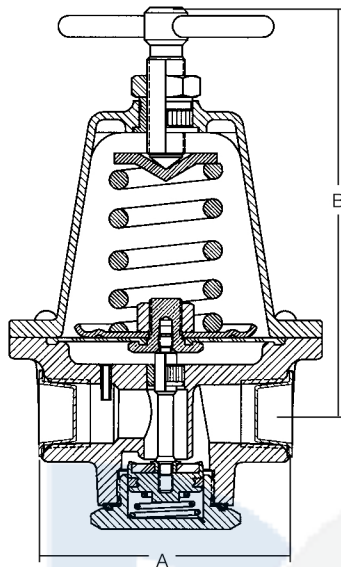

Application

Designed to reduce LP-Gas and anhydrous ammonia container pressures to between 3 and 125 PSIG. Precision-built with a multi-million BTU capacity, the 1580M series is perfect for such big, tough jobs as crop dryers, asphalt batch mixing plants, road building "tar wagons", heat treating and other large industrial and commercial loads. It's also ideal as a first stage regulator in large multiple operations. The AA1580M series is ideal for use in anhydrous ammonia applications such as blue print machines and heat treating.

Features

- Large nozzle and straight through flow provides high capacity and resistance to freeze-up.
- O-ring on retainer assembly provides a dampening effect to reduce vibration.
- Suitable for both liquid and vapor service.
- Can be readily fitted with pressure gauge in 1/4" F. NPT port.

Materials

Body Forged Aluminum
 Bonnet Die Cast Aluminum
 Spring Steel
 Valve Seat Discs Resilient Rubber
 Diaphragms Integrated Fabric and Synthetic Rubber



Ordering Information

Part Number	Service	Adjustment Method	Inlet & Outlet Connections	Recommended Delivery Pressure Range (PSIG)	A Width	B Height (max.)	Capacity Determined at Set Pressure of PSIG	Capacity**
AA1582MW	NH ₃	Tee Handle	1/4" F. NPT	3-25	2 7/16"	4 7/8"	20	2,100 CFH NH ₃
AA1582MK		Hex Head		20-50			30	2,400 CFH NH ₃
AA1582ML		Tee Handle		45-125			60	2,600 CFH NH ₃
AA1582MH								
1584VN	LP-Gas	Tee Handle	1/2" F. NPT	3-30	2 19/16"	4 7/8"	20	7,000,000 BTU/hr. LPG
1584VL				25-50			30	7,500,000 BTU/hr. LPG
1584VH				45-125			60	8,000,000 BTU/hr. LPG
AA1584VW	NH ₃	Tee Handle	1/2" F. NPT	3-25	2 19/16"	4 7/8"	20	4,500 CFH NH ₃
AA1584VL				20-50			30	4,800 CFH NH ₃
AA1584VH				45-125			60	5,100 CFH NH ₃
1586VN	LP-Gas	Tee Handle	3/4" F. NPT	3-30	3 1/2"	7"	20	11,000,000 BTU/hr. LPG
1586VL				25-50			30	12,000,000 BTU/hr. LPG
1586VH				45-125			60	14,000,000 BTU/hr. LPG
AA1586MW	NH ₃	Tee Handle	3/4" F. NPT	3-25	3 1/2"	7"	20	7,000 CFH NH ₃
AA1586VL				20-50			30	7,700 CFH NH ₃
AA1586VH				45-125			60	8,900 CFH NH ₃
1588VN	LP-Gas	Tee Handle	1" F. NPT	3-30	3 1/2"	7"	20	11,000,000 BTU/hr. LPG
1588VL				25-50			30	12,000,000 BTU/hr. LPG
1588VH				45-125			60	14,000,000 BTU/hr. LPG

* Set pressure is established with 100 PSIG inlet pressure and a flow of 500,000 BTU/hr. propane for 1580M Series, 90 CFH/hr. NH₃ for AA1582M Series and 180 CFH/hr. NH₃ for AA1584M and AA1586M Series.

** Capacities determined at actual delivery pressure 20% less than set pressure with inlet pressure 20 PSIG higher than set pressure.

NOTE: Care must be taken to prevent re-liquefaction of propane at normal temperatures by heat tracing or other effective means. Use of a relief valve upstream or downstream of these regulators is recommended in accordance with NFPA 58.