

Type 99 Pressure Reducing Regulators

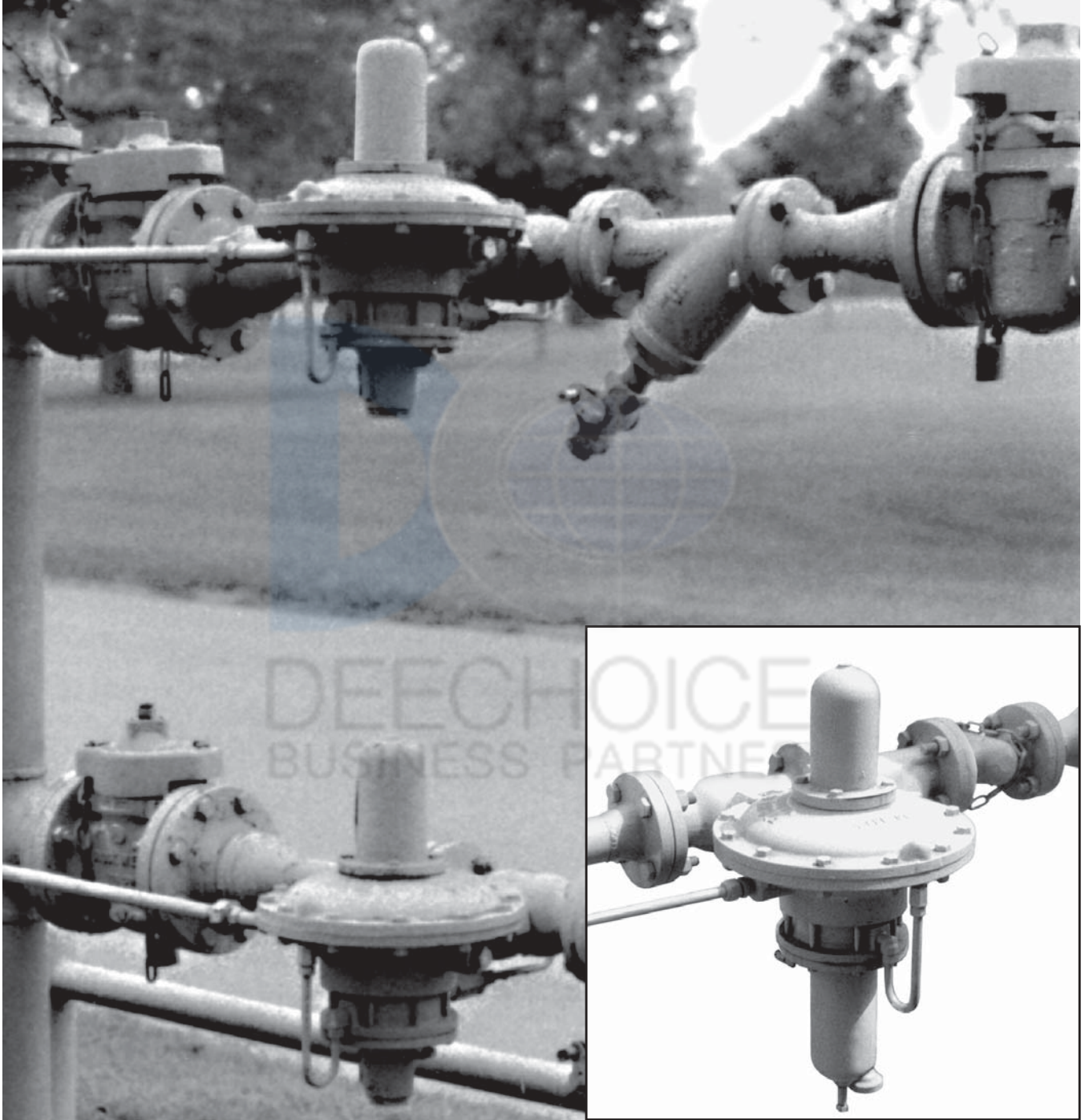

W6527
W6528

FISHER
Regulators

www.FISHERregulators.com

EMERSON
Process Management

Type 99 Pilot-Operated Pressure Reducing Regulator Features

- **Wide Variety of Applications**— Natural gas distribution systems, gas supply to industrial boilers, furnaces, ovens, mixers, plant air service, oxygen and ammonia service; and large commercial establishments such as shopping centers and schools.
- **Accuracy**—Keeps constant inlet pressures to downstream equipment by accurately controlling distribution system pressures at widely varying flow rates and supply pressures for maximum efficiency and best operation, or by eliminating the need for pressure-compensating meters by holding a steady pressure to the meter inlet.
- **No Atmospheric Bleed**—Loading pressure bleeds downstream through pilot via downstream control line. No bleed occurs when regulator is shut off.
- **Can Handle High Inlet Pressures**—Up to 1000 psig (69 bar) inlet pressures [the 1000 psig (69 bar) regulator requires a Type 1301F pilot supply regulator and a Type H110 pop relief valve].
- **Easily Modified for Special Service**—Type 61L and 61H pilot relay parts can be replaced with special orifices and springs for fast opening, fast closing, or monitoring applications.

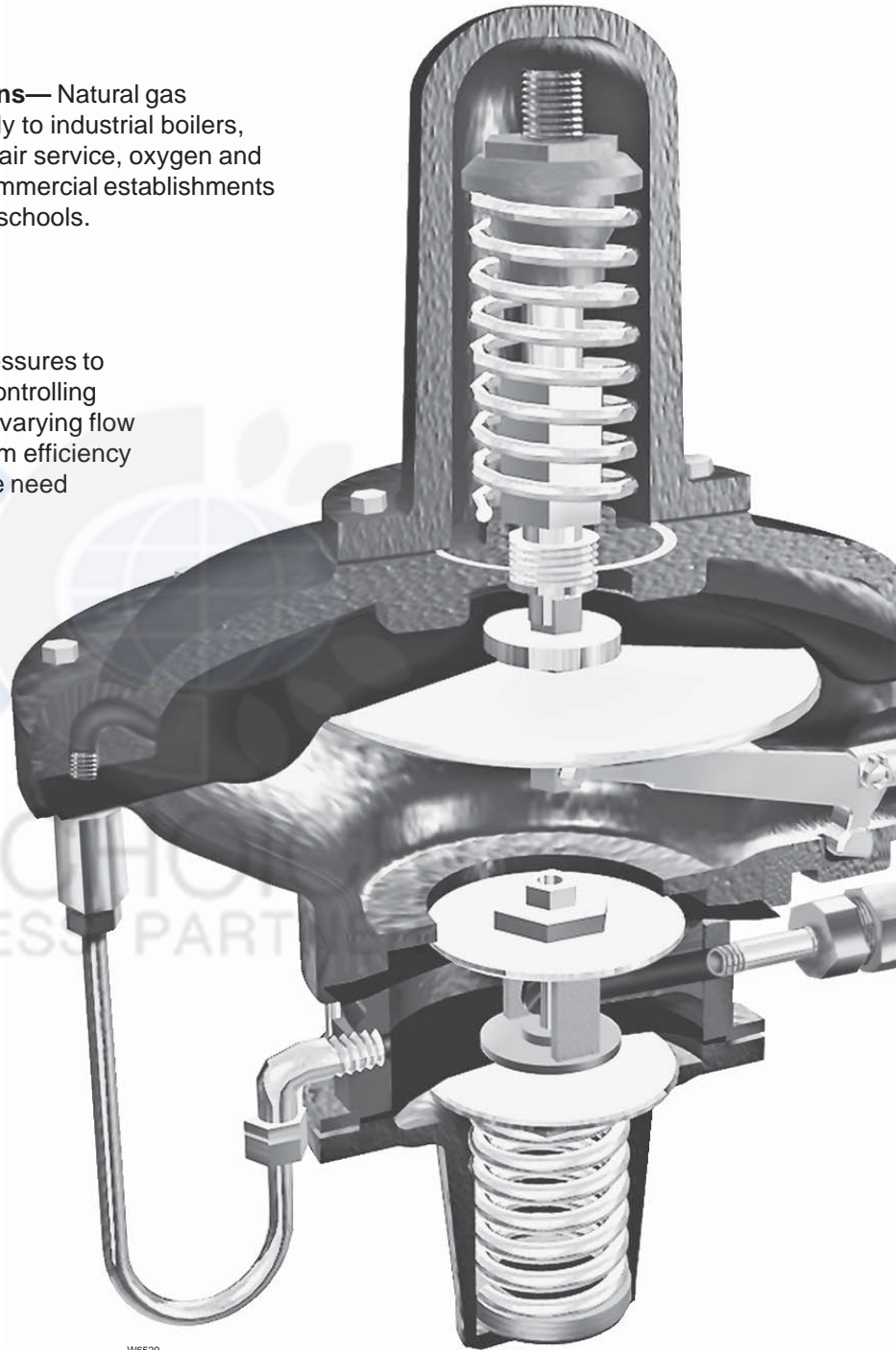

TYPE 99 REGULATOR WITH TYPE 61L
(LOW PRESSURE) PILOT

- **High-Capacity Pressure Control**—Actuator diaphragm responds quickly to downstream pressure change, causing immediate correction in main valve position. Pilot responds simultaneously and controls final positioning of main valve. This action permits full main valve travel, resulting in higher capacity than could be obtained without a pilot.

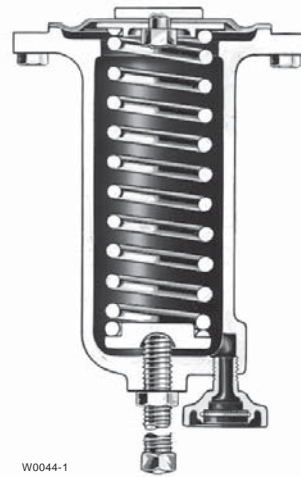

*DETAIL OF TYPE 61H PILOT
SPRING CASE (REST OF
PILOT IS LIKE TYPE 61L)*

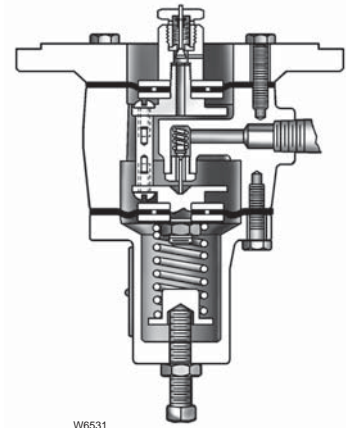

*DETAIL OF TYPE 61HP PILOT
CONSTRUCTION*

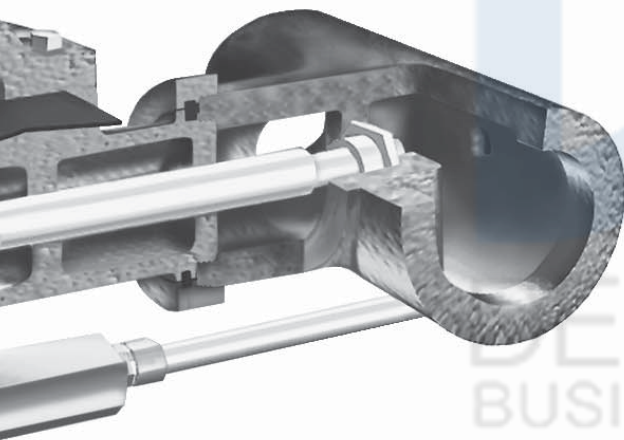

- **Tight Shutoff**—Heavy mainspring working through a lever provides a high seat loading force for tight shutoff.

- **Economical, Labor-Saving Installation**—Supply pressure to pilot is factory-piped directly from inlet side of main regulator body, thus requiring no upstream pilot supply line on standard installations.

- **Low Flow Control**—The Type 99 Regulator has a wide turn-down rangability from very low flow to high outlet pressures. Settings range from 2 inches w.c. to 100 psig (5 mbar to 6,9 bar).

- **Easy to Maintain**—Valve disk and orifice can be inspected without removing body from pipeline. Union nut connection permits quick removal of actuator and pilot from body.

- **Three Pilots to Choose From**—Type 61L (low pressure), Type 61H (high pressure), or a Type 61HP (extra high pressure). Two versions of the Type 61L are also available, Types 61LD and 61LE. Refer to Table 2 for approximate proportional bands. Pilots are integrally mounted to the actuator casing.

Specifications

Body Size and End Connection Styles

2-inch body with NPT; ANSI Class 125, 150, 250, or 300 flanged; or SWE

Maximum Allowable Inlet Pressure⁽¹⁾

160 psig (11 bar): When using Types 61LD pilot

400 psig (28 bar): When using Types 61L / 61H pilots

600 psig (41 bar): Type 61HP pilot (5/8-inch orifice maximum)

1000 psig (69 bar): Type 61HP pilot, along with Type 1301F pilot supply regulator and Type H110 relief valve (1/2-inch orifice only)

Maximum Pilot Spring Case Pressure for Pressure Loading^(1,2)

Types 61L, 61LD⁽³⁾ and 61LE⁽⁴⁾: 50 psi (3,5 bar) with special steel closing cap

Types 61H and 61HP: 100 psi (7 bar)

Outlet (Control) Pressure Ranges

See Table 1

Approximate Proportional Bands

See Table 2

Maximum Allowable Pressure Drop⁽¹⁾

See Table 3

Minimum Differential Pressure Required for Full Stroke

See Table 3

Maximum Actuator Pressures⁽¹⁾

Operating: 100 psig (6,9 bar)

Emergency: 110 psig (7,6 bar)

Flow Coefficients and Orifice Diameters

See Table 5

Typical Regulating Capacities

See Table 6

Maximum Rated Travel

1/4-inch (6,4 mm)

Temperature Capabilities⁽¹⁾

With Nitrile / Neoprene: -20° to 180°F (-29° to 82°C)

With Fluoroelastomer: 0° to 300°F (-18° to 149°C)

Type 99 Control Line and Pilot Connections

See Figure 13

Approximate Weight

115 pounds (52 kg)

Construction Materials

Actuator Casing: Cast iron

Pilot Body and Spring Case: Cast iron

Actuator Diaphragm: Nitrile or fluoroelastomer

Upper Pilot Diaphragm

Types 61L and 61H: Nitrile or fluoroelastomer

Type 61HP: Neoprene or fluoroelastomer

Lower Pilot Diaphragm

Type 61L: Nitrile or fluoroelastomer

Types 61H and 61HP: Neoprene or fluoroelastomer

Main Valve Body

400 psig (28 bar): Cast iron, Steel, or Brass (oxygen service)

600 psig (41 bar) and 1000 psig (69 bar): Steel

Metal Trim Parts for Main Valve Body

400 psig (28 bar): Brass or Stainless steel

600 psig (41 bar) and 1000 psig (69 bar): Stainless steel

Composition Seats for Main Valve Body

Disk Construction: Nitrile, Neoprene, or fluoroelastomer

O-Ring Construction: Nitrile or fluoroelastomer

Metal Trim Parts for Pilot: Steel, Stainless steel, Cast iron, Aluminum, Brass, or Zinc

Composition Seats for Pilot: Nitrile or Fluoroelastomer

Gasketing: Composition

O-Rings: Nitrile or Fluoroelastomer

P590 Series Filter

Type P594-1: Brass

Type P593-1: Aluminum

Replaceable Filter: Cellulose Tubing and Fittings

400 psig (28 bar): Copper and brass (standard), Steel, or Stainless steel on request

600 psig (41 bar) and 1000 psig (69 bar): Steel (standard) or Stainless steel on request

Type 1301F Pilot Supply Regulator

Body and Spring Case: Brass

Valve Disk: Nylon

Gasketing: Neoprene

Metal Trim Parts: Brass or Stainless steel

Type H110 Pop Relief Valve

Body: Brass

Disk: Nitrile

Spring: Stainless steel

Additional Options

- 1000 psig (69 bar) Inlet Pressure Regulator,
- Oxygen or Ammonia Service (with special construction),
- O-Ring Stem Seal for Monitor Regulator,
- Travel Indicator,
- Electronic Remote Control Capability Handwheel for Type 61L Pilot

1. The pressure/temperature limits in this bulletin and any applicable standard or code limitation should not be exceeded.

2. For stability or overpressure protection, a pilot supply regulator may be installed in the pilot supply tubing between the main valve and pilot.

3. Type 61LD construction has narrower proportional band than does the standard Type 61L pilot.

4. Type 61LE construction has broader proportional band than does the standard Type 61L pilot.

Table 1. Outlet Pressure Ranges

PILOT TYPE	MAXIMUM PILOT SUPPLY PRESSURE, PSIG (bar)	OUTLET (CONTROL) PRESSURE RANGES	PILOT CONTROL SPRING			
			Part Number	Color Code	Wire Diameter, Inches (cm)	Free Length, Inches (cm)
61L	400 (27,6)	2 to 4-inches w.c. (5 to 10 mbar) 3 to 12-inches w.c. (7 to 30 mbar) 0.25 to 2 psig (17 to 138 mbar) 1 to 5 psig (0,069 to 0,34 bar) 2 to 10 psig (0,14 to 0,69 bar) 5 to 15 psig (0,34 to 1,0 bar) 10 to 20 psig (0,69 to 1,4 bar)	1B558527052	Orange	0.075 (0,19)	4-1/8 (10,5)
61LD ⁽¹⁾	160 (11)		1C680627222	Unpainted	0.080 (0,20)	3-1/4 (8,3)
61LE ⁽²⁾	400 (27,6)		1B886327022	Red	0.109 (0,28)	2-3/4 (7,0)
			1J857827022	Yellow	0.142 (0,36)	2-3/4 (7,0)
61H	400 (27,6)	1B88642072	Blue	0.172 (0,44)	2-7/8 (7,3)	
61HP	600 (41)	10 to 65 psig (0,69 to 4,5 bar)	1J857927142	Brown	0.187 (0,47)	2-7/8 (7,3)
			1B886527022	Green	0.363 (0,92)	3-1/8 (7,9)
61H	400 (27,6)	10 to 65 psig (0,69 to 4,5 bar)	0Y0664000A2	Green stripe	0.363 (0,92)	6 (15,2)
61HP	600 (41)	35 to 100 psig (2,4 to 6,9 bar)	1D387227022	Blue	0.200 (0,51)	1-11/16 (4,3)

1. Type 61LD construction has narrower proportional band than does the standard Type 61L Pilot.
2. Type 61LE construction has broader proportional band than does the standard Type 61L Pilot.

Table 2. Proportional Bands

PILOT TYPE	PILOT CONTROL SPRING				PROPORTIONAL BANDS
	Part Number	Color Code	Wire Diameter, Inches (cm)	Free Length, Inches (cm)	
61LD	1B558527052	Orange	0.075 (0,19)	4-1/8 (10,5)	0.1 to 0.5-inches w.c. (0,25 to 1,2 mbar)
	1C680627222	Unpainted	0.080 (0,20)	3-1/4 (8,3)	
61L	1B886327022	Red	0.109 (0,28)	2-3/4 (7,0)	1 to 2-inches w.c. (2,5 to 5 mbar)
61LD	1B886327022	Red	0.109 (0,28)	2-3/4 (7,0)	0.25 to 1-inches w.c. (0,62 to 2,5 mbar)
61LE	1B886327022	Red	0.109 (0,28)	2-3/4 (7,0)	5 to 8-inches w.c. (12 to 20 mbar)
61L, 61LD, 61 LE	1B886527022	Green	0.207 (0,53)	3-1/8 (7,9)	0.1 to 0.3 psi (6,9 to 21 mbar)
	1J857927142	Brown	0.187 (0,47)	2-7/8 (7,3)	
	1B886427022	Blue	0.172 (0,44)	2-7/8 (7,3)	
	1J857827022	Yellow	0.142 (0,36)	2-3/4 (7,0)	
61H	0Y0664000A2	Green stripe	0.363 (0,92)	6 (15,2)	0.1 to 0.3 psi (6,9 to 21 mbar)
61HP	1D387227022	Blue	0.200 (0,51)	1-11/16 (4,3)	1 to 2 psi (69 to 138 mbar)

Table 3. Maximum Allowable Drop and Minimum Differential Pressures

MAXIMUM ALLOWABLE PRESSURE DROP, PSIG (bar)	MAIN VALVE SPRING			MINIMUM DIFFERENTIAL PRESSURE FOR FULL STROKE, PSIG (bar)	SEAT MATERIAL	MAXIMUM PORT DIAMETER ⁽¹⁾ , Inches (mm)
	Part Number	Wire Diameter, Inches (cm)	Free Length, Inches (cm)			
25 (1,7)	1C277127022	0.148 (0,38)	6 (15,2)	0.75 (0,052)	Nitrile, Neoprene, Fluoroelastomer	1-1/8 (28,6)
50 (3,4)	1N801927022	0.156 (0,40)	7-1/8 (18,1)	1.5 (0,10)	Nitrile, Neoprene, Fluoroelastomer	1-1/8 (28,6)
150 (10,3)	1B883327022	0.187 (0,47)	6-5/8 (17,0)	3 (0,21)	Nitrile, Neoprene, Fluoroelastomer	1-1/8 (28,6)
175 (12,1)	1B883327022	0.187 (0,47)	6-5/8 (17,0)	3 (0,21)	Nitrile ⁽²⁾ , Neoprene ⁽²⁾ , Fluoroelastomer ⁽²⁾	7/8 (22,2)
	1B883327022	0.187 (0,47)	6-5/8 (17,0)	3 (0,21)	Nitrile, Fluoroelastomer	7/8 (22,2)
250 (17,2)	0W019127022	0.281 (0,71)	6 (15,2)	10 (0,69)	Nitrile ⁽³⁾ , Fluoroelastomer ⁽³⁾	1-1/8 (28,6)
300 (20,7)	0W019127022	0.281 (0,71)	6 (15,2)	10 (0,69)	Nylon	1-1/8 (28,6)
400 (27,6)	0W019127022	0.281 (0,71)	6 (15,2)	10 (0,69)	Nylon	7/8 (22,2)
600 (41)	0W019127022	0.281 (0,71)	6 (15,2)	10 (0,69)	Nylon	5/8 (15,9)
1000 (69)	0W019127022	0.281 (0,71)	6 (15,2)	10 (0,69)	Nylon	1/2 (12,7) ⁽⁴⁾

1. Can use all port diameters up to maximum size listed.
2. ANSI Class 125 FF flanged body only.
3. O-ring seat only.
4. 1/2 inch (12,7 mm) is the only seat ring available for 1000 psig (69,0 bar) maximum inlet pressure regulator.

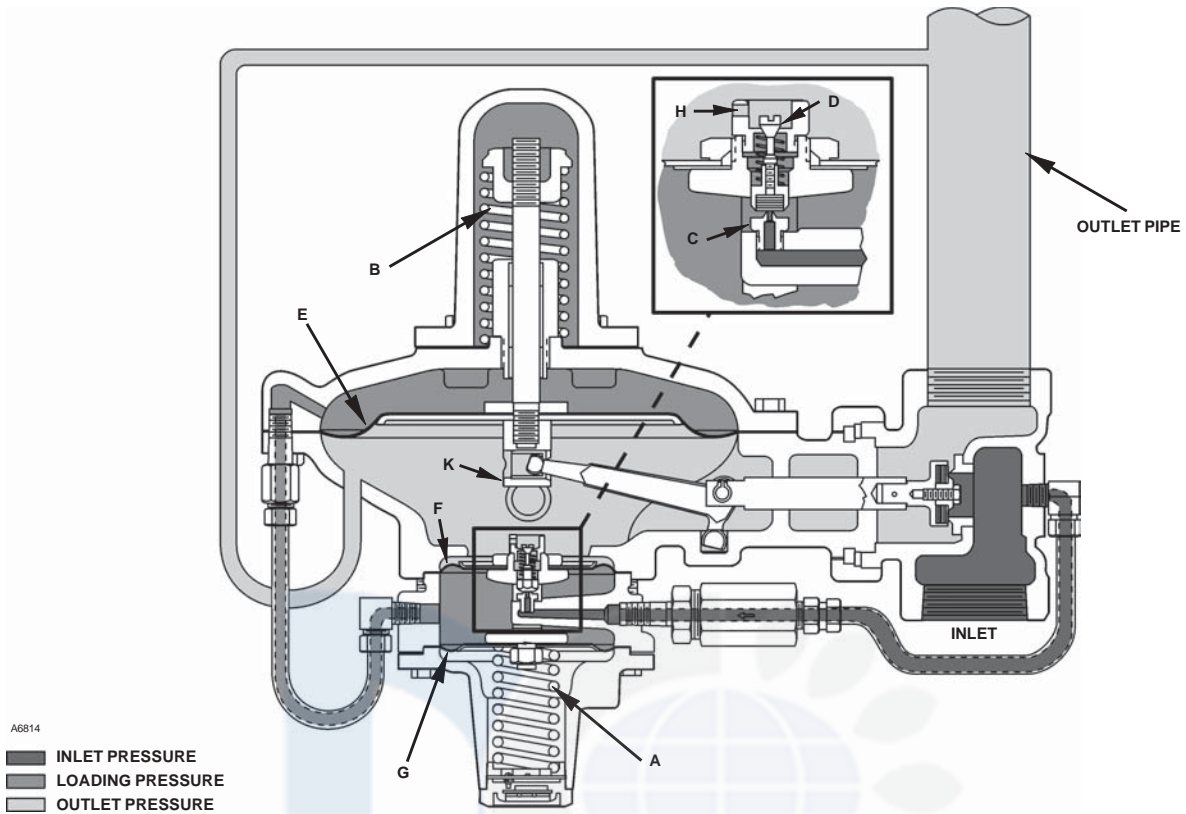

Figure 3. Schematic of Type 99 Regulator with Type 61L (low pressure) Pilot

Principle of Operation

The key to the operation of a Type 99 regulator is the yoked double-diaphragm pilot (letter keys in this section refer to both figure 3 and 4 unless otherwise noted). Fast response and accuracy are made possible by the amplifying effect of the pressure-balanced pilot and by the two-path control system. The function of the pilot is to sense change in the controlled pressure and amplify it into a larger change in the loading pressure. Any changes in outlet pressure act quickly on both the actuator diaphragm and the loading pilot, thus providing the precise pressure control that is characteristic of a two-path system.

A typical pilot has an approximate gain of 20, which means the outlet pressure needs to droop only 1/20 as much as a self-operated regulator in order to obtain the same pressure differences across the main diaphragm. Advantages of a pilot operated regulator are high accuracy and high capacity.

Upstream or inlet pressure is utilized as the operating medium, which is reduced through pilot operation to load the main diaphragm chamber. Tubing connects the inlet

pressure to the pilot through a filter assembly. Downstream or outlet pressure registers underneath main diaphragm (E) through the downstream control line.

In operation, assume the outlet pressure is less than the setting of pilot control spring (A). The top side of pilot diaphragm assembly (F) will have a lower pressure than the setting of spring (A). Spring (A) forces the diaphragm head assembly upward, opening the relay or inlet orifice (C). Additional loading pressure is supplied to the pilot body and to the top side of main diaphragm (E).

This creates a higher pressure on the top side of main diaphragm (E) than on the bottom side, forcing the diaphragm downward. This motion is transmitted through a lever, which pulls the valve disk open, allowing more gas to flow through the valve.

When the gas demand in the downstream system has been satisfied, the outlet pressure increases. The increased pressure is transmitted through the downstream control line and acts on top of the pilot diaphragm head assembly (F). This pressure exceeds the pilot spring setting and forces the head assembly down, closing orifice (C). The loading pressure acting on main

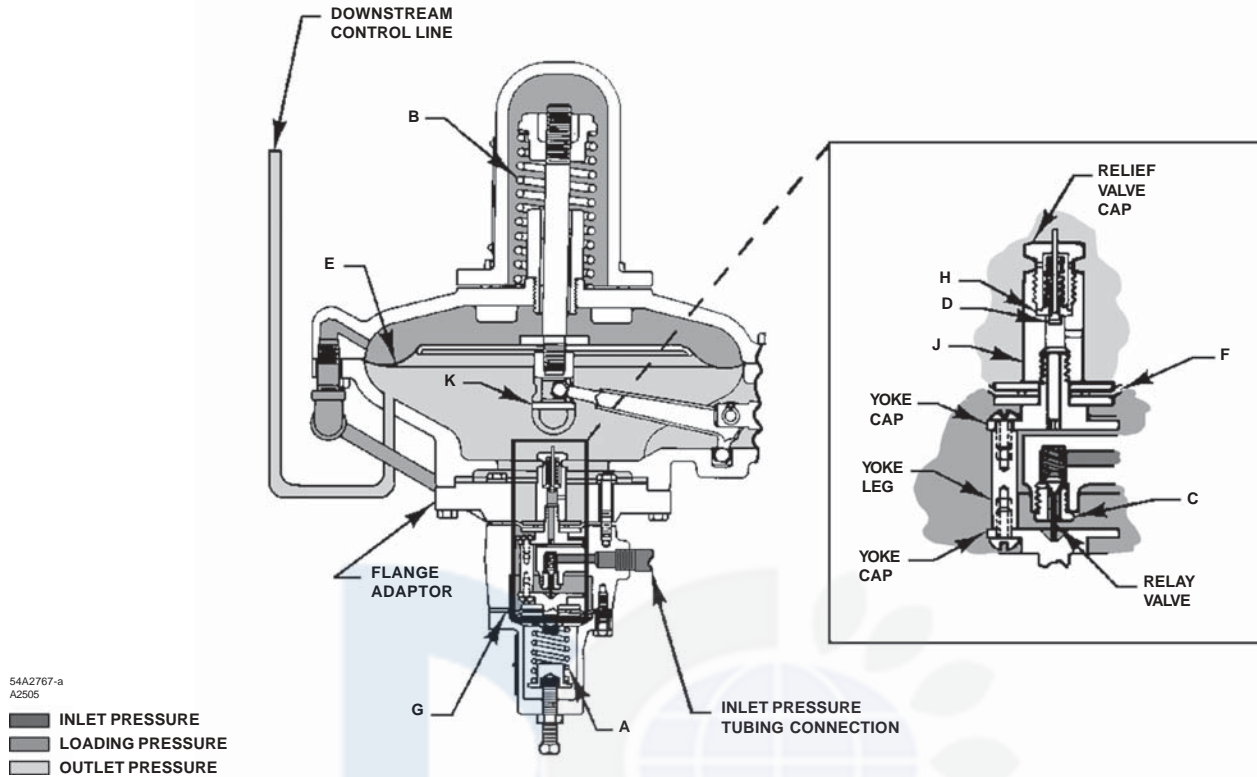

Figure 4. Schematic of Type 99 Regulator with Type 61HP (extra high pressure) Pilot

diaphragm (E) bleeds to the downstream system through a small slot between the pilot bleed valve (D) and bleed orifice (H).

Normally, excess loading pressure slowly escapes downstream around bleed valve (D) (figure 3) or through the relief valve body (J) (figure 4). Since loading pressure need exceed outlet pressure only moderately to stroke the main valve fully open, a continued increase in loading pressure differential extends main diaphragm (E) and pusher post assembly (K) far enough to separate bleed valve (D) and bleed orifice (H). This permits quick dumping of excess loading pressure into the downstream system.

With a decrease in loading pressure on top of main diaphragm (E), main spring (B) exerts an upward force on the diaphragm rod connected to main diaphragm (E), pulling it upward. This moves the main valve toward its seat, decreasing flow to the downstream system.

Diaphragm (G) in the pilot valve acts as a sealing member for the loading chamber and as a balancing member to diaphragm (F). These two diaphragms are connected by a yoke so any pressure change in the

pilot chamber has little effect on the position of the pilot valve. Therefore, the active diaphragm in the pilot is (F) and the pressure on the top side of this diaphragm opposes the force of the pilot control spring (A).

Construction Features

Pilot Interchangeability

When higher or lower pressure control is needed, the existing pilot can be exchanged for one that provides the desired range.

Type 99 lower castings accept either low or high pressure pilots without requiring separate mounting parts for each construction. When converting to an extra high pressure unit, an additional flange adaptor will be required.

When a Type 61L (low pressure) pilot is ordered for field conversion to a Type 61H (high pressure) pilot or vice versa, the replacement pilot assembly comes complete with a pilot cover that must be removed before installing the replacement pilot on the existing regulator. The

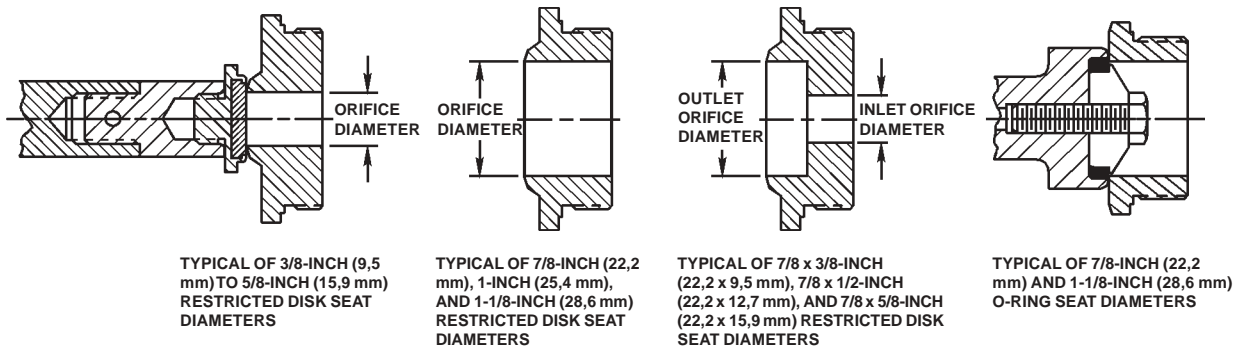

Figure 5. Type 99 Orifice Construction

cover can then be installed on the removed pilot to form a complete Type 61L (low pressure) pilot or Type 61H (high pressure) pilot for use elsewhere.

Choice of Shutoff

The Type 99 regulator body comes with either a composition disk that seats against a knife-edged orifice (figure 3 or 5), or a composition O-ring that seats against a flat orifice (figure 5).

O-ring seats should be used when heavier main springs, larger orifice sizes and higher inlet pressures are encountered. The O-ring adapter will also seat against the orifice face creating a mechanical stop, where the knife-edged orifice can possibly cut through a disk damaging the seat and losing a tight shutoff.

The 1000 psig (69 bar) maximum inlet pressure regulator comes standard with a 1/2 inch (12,7 mm) disk seat, while lower inlet Type 99 regulators have a choice of three different restricted-diameter orifices and eight different straight-bore orifices for unusually light loads or for minimizing relief requirements.

1000 Psig (69 Bar) Inlet Pressure Capability

The 1000 psig (69 bar) maximum inlet pressure regulator must have its Type H110 pop relief valve installed directly, or remotely by means of piping and a female threaded coupling, into the 1/4-inch NPT side outlet of the supply regulator. The pilot supply regulator reduces inlet pressure to a usable 200 psig (14 bar) for the integral Type 61HP (extra high pressure) pilot. The relief valve is set to relieve if the reduced pressure from the pilot supply regulator exceeds 225 psig (16 bar). This Type 99 regulator comes standard with O-ring seals on the guide bushing and valve carrier assembly to keep the



Figure 6. Optional Travel Indicator

main valve body outlet pressure from interfering with outlet pressure registration in the lower actuator casing.

Rugged Service Capability

High-temperature elastomers provide service capabilities up to 300°F (149°C). Brass body and fluoroelastomer seat can be provided for special service requirements. Stainless steel trims and an aluminum filter can be ordered where hydrogen sulfide or other contaminants are present in the gas and no brass or copper can be permitted.

Travel Indicator

An optional travel indicator (figure 6) consists of an actuator spring case with an integrally cast indicator housing, an indicator disk enclosed in a clear housing, and an indicator plate graduated in percent of valve opening. This indicator assembly provides the capability to inspect for smooth travel without removing the regulator from service.



Figure 7. Optional Type 662 Kixel® Remote Drive

Electronic Remote Control Capability

Where remote adjustment of the pilot control spring setting is desired, Type 662 Kixel® drive units (figure 7) that mount to the pilot and accept a variety of electrical inputs are available. The Type 662 Kixel remote drive unit uses electronic signals to switch its motor on and off which turns the pilot adjusting screw, changing spring compression to increase or decrease outlet pressure. The design provides smooth, highly accurate positioning with positive-lock when the unit is not in motion.

Oxygen and Ammonia Service

The Type 99 regulator can be manufactured for Oxygen or Ammonia service:

- **For Oxygen Service**— All metal parts that are in contact with immediate flow stream are made from materials suitable for oxygen. The construction includes a screwed bronze body, brass lower casing protector, fluoroelastomer diaphragms and O-rings. The seat construction is a O-ring design seat. Oxygen cleaning is typically required whenever the oxygen service construction is required.

- **For Ammonia Service**— The Type 99 regulator may be used by removing all brass parts. The stainless steel trim option should be selected which eliminates any brass parts. The standard nitrile elastomers are suitable for ammonia service up to their specified temperature range.

Pressure Loading Flexibility

Type 99 pilot spring cases can be pressure loaded for applications involving differential pressure control or

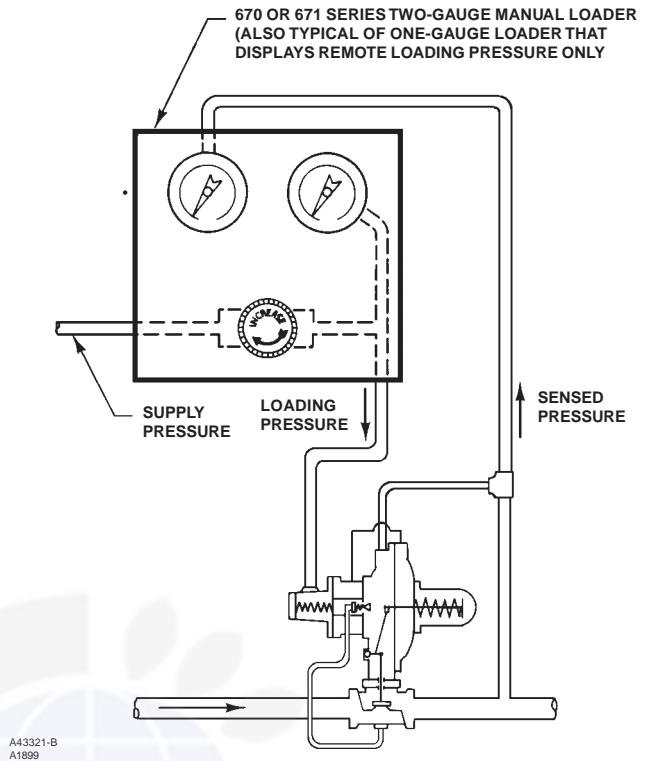

Figure 8. Pneumatic Remote Adjustment Installation

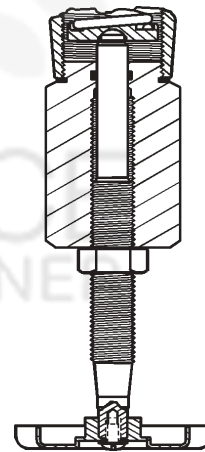

Figure 9. Type 61L (low pressure) Handwheel

remote pneumatic adjustment of the downstream pressure setting (figure 8). If loading pressure fails, outlet pressure will be maintained at the pilot control spring setting.

Pilots are provided with a 1/4-inch NPT tapped connection in the spring case. Low pressure pilots additionally can be furnished with a handwheel (figure 9) for precise trimming of the final pressure setting. Outlet pressure is the sum of the spring setting and the loading pressure.

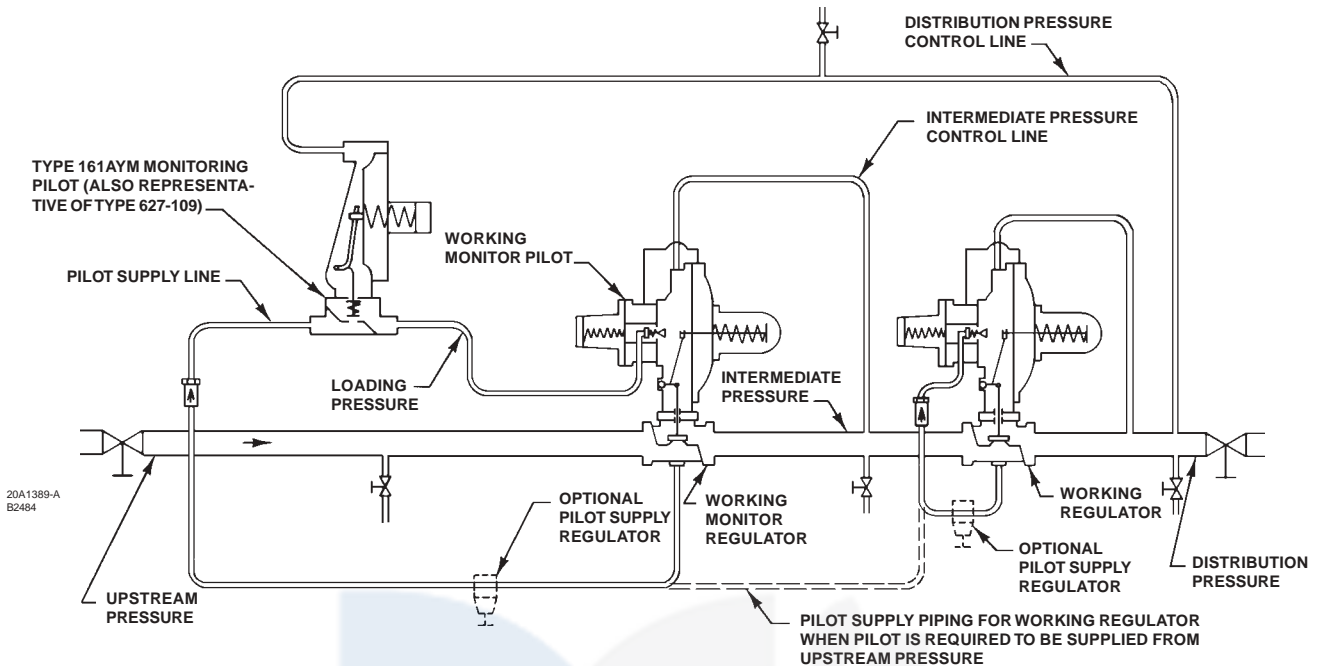

Figure 10. Working Monitor Installation

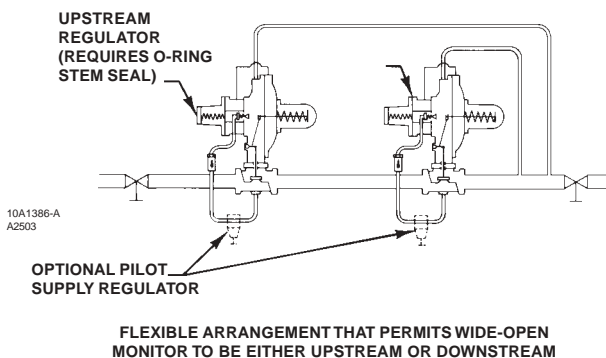
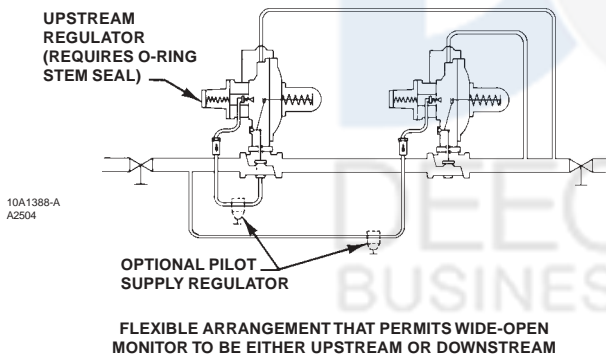

Figure 11. Typical Wide-Open Monitor Installations

Monitoring Systems for Safety

Monitoring regulators serve as overpressure protection devices to limit system pressure in the event of open failure of a working regulator feeding the system. Two methods of using Type 99 regulators in monitoring systems are as follows:

- Working Monitor**—On a working monitor installation (figure 10), the control line of the monitoring pilot is connected downstream of the working regulator. During normal operation, distribution pressure causes the monitoring pilot to stand wide open. Full pilot supply pressure enters the working monitor pilot and permits the working monitor regulator to control at its intermediate pressure setting.

Open failure of the working regulator increases distribution pressure as the working regulator goes wide open. Intermediate pressure is then ignored by the monitoring regulator, which controls downstream pressure at its own pressure setting (slightly higher than the normal control pressure).

The monitoring pilot should be upstream of the working monitor regulator. This enables a closer set point between the working regulator and the monitoring pilot. Special Type 161AYW and 627-109 monitoring pilots with quick-bleed operation have been designed to give

Table 4. Working Monitor Performance

Construction	Spring Range	MONITORING PILOT INFORMATION			MINIMUM PRESSURE AT WHICH WORKING MONITOR REGULATOR CAN BE SET
		Part Number	Pilot Spring Wire Diameter, Inch (cm)	Free Length, Inches (cm)	
Type 161AYW with 1/8-inch (3,2 mm) port diameter and 150 psig (10,3 bar) maximum allowable inlet pressure	5 to 15-inches w.c. (12 to 38 mbar) 11 to 28-inches w.c. (27 to 68 mbar)	1B653927022 1B537027052	0.105 (0,027) 0.114 (0,30)	3-3/4 (9,5) 4-5/16 (11,0)	3-inches w.c. (7 mbar) over normal distribution pressure
	1 to 2.5 psig (0,069 to 0,17 bar) 2.25 to 4.5 psig (0,16 to 0,31 bar) 4-1/2 to 7 psig (0,31 to 0,48 bar)	1B537127022 1B537227022 1B537327052	0.156 (0,39) 0.187 (0,47) 0.218 (0,55)	4-1/8 (10,4) 3-15/16 (10,0) 4-1/8 (10,4)	0.5 psi (0,034 bar) over normal distribution pressure
	5 to 15 psig (0,34 to 1,0 bar) 10 to 25 psig (0,69 to 1,7 bar) 20 to 35 psig (1,4 to 2,4 bar) 25 to 60 psig (1,7 to 4,1 bar)	1D892327022 1D751527022 1D665927022 1D755527142	0.168 (0,43) 0.187 (0,47) 0.218 (0,55) 0.500 (1,30)	2-15/16 (7,5) 2-13/16 (7,1) 2-15/32 (6,3) 9-1/4 (23,5)	3.0 psi (0,021 bar) over normal distribution pressure
Type 627-109 with 1/8-inch (3,2 mm) port diameter and 150 psig (10,3 bar) maximum allowable inlet pressure for cast iron body or 750 psig (52 bar) maximum allowable inlet pressure for malleable iron body	40 to 80 psig (2,8 to 5,5 bar) 80 to 150 psig (5,5 to 10,3 bar) 130 to 200 psig (9,0 to 13,8 bar)	1E543627142 1P901327142 ⁽¹⁾ 1P901327142 ⁽²⁾	0.283 (0,72) 0.240 (0,61) 0.240 (0,61)	2-15/16 (5,9) 2-5/8 (6,7) 2-5/8 (6,7)	5.0 psi (0,34 bar) over normal distribution pressure

1. With large diaphragm plate.
2. With small diaphragm plate.

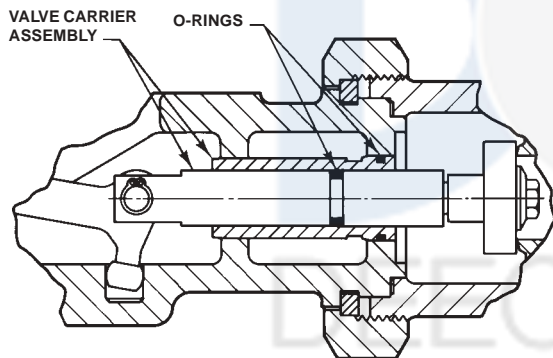

Figure 12. O-Ring Seal Construction

faster response to abnormal downstream conditions. Table 4 gives the spread between normal distribution pressure and the minimum pressure at which the working monitor regulator can be set to take over if the working regulator fails open.

- **Wide Open Monitor**—The control line of the upstream regulator is connected downstream of the second regulator (figure 11), so that during normal operation the monitoring regulator is standing wide open with the reduction to distribution pressure being taken across the working regulator. Only in case of open failure of the working regulator does the wide-open monitoring regulator take control at its slightly higher setting.

The upstream regulator must be ordered with an O-ring seal (figure 12) on the valve carrier assembly. This

seals off the leak path that otherwise would let line pressure ahead of the working regulator inlet try to close the wide-open monitoring regulator.

Overpressure Protection

Like most regulators, the Type 99 has outlet pressure ratings lower than the inlet pressure ratings. Complete downstream overpressure protection is needed if the actual inlet pressure exceeds the outlet pressure rating.

On the 1000 psig (69 bar) maximum inlet pressure regulator the Type H110 relief valve provides sufficient relief capacity to protect the Type 61HP (extra high pressure) pilot in case the Type 1301F pilot supply regulator fails open. This protection is insufficient if the main valve fails open, downstream overpressure protection is still needed.

Overpressuring any portion of a regulator or associated equipment may cause leakage, part damage, or personal injury due to bursting of pressure containing parts or explosion of accumulated gas. Regulator operation within ratings does not preclude the possibility of damage from external sources or from debris in the pipeline. A regulator should be inspected for damage periodically and after any overpressure condition.

Table 5. Flow Coefficients and Orifice Diameters

TRIM CONSTRUCTION	PORT DIAMETER, INCHES (mm)	FOR RELIEF SIZING WIDE-OPEN C _g	REGULATING C _g
Restricted capacity trim, Straight bore — Composition or Nylon disk seat only	3/8 (9,5)	115	90
	1/2 (12,7) ⁽¹⁾	200	155
	9/16 (14,3)	235	188
	5/8 (15,9)	300	216
	3/4 (19,1)	425	330
Restricted capacity trim, Stepped bore — Composition or Nylon disk seat only	7/8 x 3/8 (22,2 x 9,5)	115	110
	7/8 x 1/2 (22,2 x 12,7)	200	190
	7/8 x 5/8 (22,2 x 15,9)	300	280
Full capacity trim, Composition or Nylon disk, or O-ring seat	7/8 (22,2)	550	408
	1 (25,4)	680	550
	1-1/8 (28,6)	850	680

1. 1/2-inch (12,7 mm) is the only port diameter available for 1000 psig (69 bar) maximum inlet pressure regulator.

Capacity Information

Note

Flow capacities are laboratory verified; therefore, regulators may be sized for 100% flow published capacities. It is not necessary to reduce published capacities.

Table 6 gives standard full-capacity Type 99 natural gas regulating capacities at selected inlet pressures and outlet pressure settings. Flows are in thousands of scfh (at 60°F and 14.7 psia) and of m³/h(n) (at 0°C and 1.01325 bar) of 0.6 specific gravity gas. To determine equivalent capacities for air, propane, butane, or nitrogen, multiply the scfh table 6 capacity by the following appropriate conversion factor: 0.775 for air, 0.628 for propane, 0.548 for butane, or 0.789 for nitrogen. For gases of other specific gravities, multiply the given capacity by 0.775 and divide by the square root of the appropriate specific gravity. Then, if capacity is desired in m³/h(n), multiply scfh by 0.0268.

To obtain the published capacities, the inlet and outlet piping should be the same as the regulator body size.

To find approximate regulating capacities at pressure settings not given in table 6 or to find wide-open flow capacities for relief sizing at any inlet pressure, perform one of the following procedures. Then, if necessary, convert using the factors provided above.

For critical pressure drops (absolute outlet pressure equal to or less than one-half of absolute inlet pressure), use the following formula:

$$Q = (P_1)(C_g)(1.29)$$

For pressure drops lower than critical (absolute outlet pressure greater than one-half of absolute inlet pressure).

$$Q = \sqrt{\frac{520}{GT}} C_g P_1 \text{SIN} \left(\frac{3417}{C_1} \sqrt{\frac{\Delta P}{P_1}} \right) \text{DEG}$$

where,

Q = gas flow rate, scfh

P₁ = absolute inlet pressure, psia (P₁ gauge + 14.7)

C_g = regulating or wide-open gas sizing coefficient from table 5

G = gas specific gravity of the gas

T = absolute temperature of gas at inlet, °Rankine

C₁ = flow coefficient

ΔP = pressure drop across the regulator, psi

Then, if capacity is desired in normal cubic meters per hour at 0°C and 1,01325 bar, multiply scfh by 0.0268.

Installation

Although the union nut permits the actuator and pilot to be mounted in any position relative to the body, the normal installation is with the body in a horizontal run of pipe and the pilot hanging vertically from the bottom of the actuator as shown in figure 1.

Control and vent lines necessary for installation are not supplied with a Type 99 regulator. Control and vent connection locations are shown in figure 13. In many instances good piping practice will require that outlet piping be swaged up above the body size to prevent excessive pressure drop along the outlet line. The piping should be expanded as close to the regulator outlet as possible.

Dimensional information also is given in figure 13.

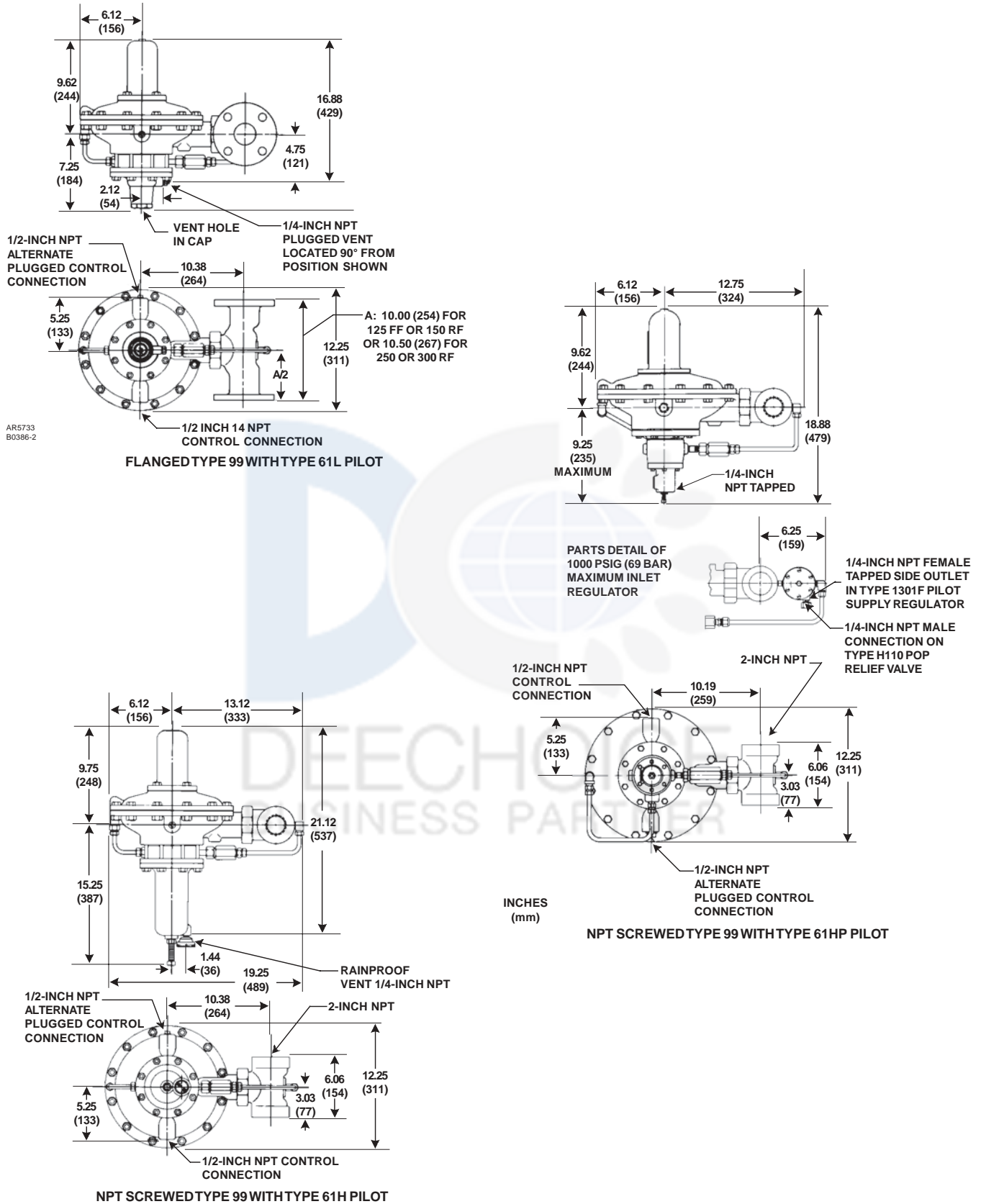

Figure 13. Type 99 Dimensions

Bulletin 71.2:99

Table 6. Capacities⁽¹⁾ in Thousands of SCFH (m³/h(n)) of 0.6 Specific Gravity Gas⁽²⁾ for Full-Capacity Type 99 Regulators

SEAT RING SIZE, INCHES (mm)	INLET PRESSURE, PSIG (bar)	CAPACITIES ⁽¹⁾ IN THOUSANDS OF SCFH (m ³ /h(n)) OF 0.6 SPECIFIC GRAVITY NATURAL GAS												
		Outlet Pressure, psig (bar)												
		0.25 (0,02)	0.5 (0,03)	1 (0,069)	2 (0,14)	3 (0,21)	4 (0,28)	5 (0,34)	6 (0,41)	7 (0,48)	8 (0,55)	9 (0,62)	10 (0,69)	
7/8 (22,2)	5 (0,34)	7.2 (0,2)	7.2 (0,2)	6.6 (0,2)	6.0 (0,2)									
	6 (0,41)	7.8 (0,2)	7.8 (0,2)	7.8 (0,2)	7.8 (0,2)	6.6 (0,2)								
	7 (0,48)	9.0 (0,2)	9.0 (0,2)	9.0 (0,2)	9.0 (0,2)	7.2 (0,2)	6.6 (0,2)							
	8 (0,55)	9.6 (0,3)	9.6 (0,3)	9.6 (0,3)	9.6 (0,3)	7.8 (0,2)	7.2 (0,2)	6.6 (0,2)						
	9 (0,62)	10 (0,3)	10 (0,3)	10 (0,3)	10 (0,3)	9 (0,2)	8.4 (0,2)	7.2 (0,2)	6.6 (0,2)					
	10 (0,69)	11.4 (0,3)	11.4 (0,3)	10.8 (0,3)	10 (0,3)	9.6 (0,3)	9.0 (0,2)	8.4 (0,2)	7.8 (0,2)	7.2 (0,2)				
	15 (1,0)	14.4 (0,4)	14.4 (0,4)	14.4 (0,4)	14.4 (0,4)	14.4 (0,4)	13.8 (0,4)	13.2 (0,4)	13.2 (0,4)	12 (0,3)	12 (0,3)	12 (0,3)	11.4 (0,3)	7.8 (0,2)
	20 (1,4)	18.6 (0,5)	18.6 (0,5)	18.6 (0,5)	18.6 (0,5)	18.6 (0,5)	18.6 (0,5)	18.6 (0,5)	18 (0,5)	16.8 (0,5)	16.2 (0,4)	15.6 (0,4)	15 (0,4)	14.4 (0,4)
	25 (1,7)	21 (0,6)	21 (0,6)	21 (0,6)	21 (0,6)	21 (0,6)	21 (0,6)	21 (0,6)	21 (0,6)	21 (0,6)	21 (0,6)	19.8 (0,5)	19.8 (0,5)	19.2 (0,5)
	30 (2,1)	23 (0,6)	23 (0,6)	23 (0,6)	23 (0,6)	23 (0,6)	23 (0,6)	23 (0,6)	23 (0,6)	23 (0,6)	23 (0,6)	23 (0,6)	23 (0,6)	23 (0,6)
	35 (2,4)	26 (0,7)	26 (0,7)	26 (0,7)	26 (0,7)	26 (0,7)	26 (0,7)	26 (0,7)	26 (0,7)	26 (0,7)	26 (0,7)	26 (0,7)	26 (0,7)	26 (0,7)
	40 (2,8)	28 (0,8)	28 (0,8)	28 (0,8)	28 (0,8)	28 (0,8)	28 (0,8)	28 (0,8)	28 (0,8)	28 (0,8)	28 (0,8)	28 (0,8)	28 (0,8)	28 (0,8)
	50 (3,4)	34 (0,9)	34 (0,9)	34 (0,9)	34 (0,9)	34 (0,9)	34 (0,9)	34 (0,9)	34 (0,9)	34 (0,9)	34 (0,9)	34 (0,9)	34 (0,9)	34 (0,9)
	60 (4,1)	42 (1,1)	42 (1,1)	42 (1,1)	42 (1,1)	42 (1,1)	42 (1,1)	42 (1,1)	42 (1,1)	42 (1,1)	42 (1,1)	42 (1,1)	42 (1,1)	42 (1,1)
	75 (5,2)	47 (1,3)	47 (1,3)	47 (1,3)	47 (1,3)	47 (1,3)	47 (1,3)	47 (1,3)	47 (1,3)	47 (1,3)	47 (1,3)	47 (1,3)	47 (1,3)	47 (1,3)
	100 (6,9)	59 (1,6)	59 (1,6)	59 (1,6)	59 (1,6)	59 (1,6)	59 (1,6)	59 (1,6)	59 (1,6)	59 (1,6)	59 (1,6)	59 (1,6)	59 (1,6)	59 (1,6)
	125 (8,6)	73 (2,0)	73 (2,0)	73 (2,0)	73 (2,0)	73 (2,0)	73 (2,0)	73 (2,0)	73 (2,0)	73 (2,0)	73 (2,0)	73 (2,0)	73 (2,0)	73 (2,0)
	150 (10,3)	86 (2,3)	86 (2,3)	86 (2,3)	86 (2,3)	86 (2,3)	86 (2,3)	86 (2,3)	86 (2,3)	86 (2,3)	86 (2,3)	86 (2,3)	86 (2,3)	86 (2,3)
	175 (12,0)	96 (2,6)	96 (2,6)	96 (2,6)	96 (2,6)	96 (2,6)	96 (2,6)	96 (2,6)	96 (2,6)	96 (2,6)	96 (2,6)	96 (2,6)	96 (2,6)	96 (2,6)
	200 (13,8)	108 (2,9)	108 (2,9)	108 (2,9)	108 (2,9)	108 (2,9)	108 (2,9)	108 (2,9)	108 (2,9)	108 (2,9)	108 (2,9)	108 (2,9)	108 (2,9)	108 (2,9)
225 (16,0)	123 (3,3)	123 (3,3)	123 (3,3)	123 (3,3)	123 (3,3)	123 (3,3)	123 (3,3)	123 (3,3)	123 (3,3)	123 (3,3)	123 (3,3)	123 (3,3)	123 (3,3)	
250 (17,2)	132 (3,5)	132 (3,5)	132 (3,5)	132 (3,5)	132 (3,5)	132 (3,5)	132 (3,5)	132 (3,5)	132 (3,5)	132 (3,5)	132 (3,5)	132 (3,5)	132 (3,5)	
300 (20,7)	162 (4,3)	162 (4,3)	162 (4,3)	162 (4,3)	162 (4,3)	162 (4,3)	162 (4,3)	162 (4,3)	162 (4,3)	162 (4,3)	162 (4,3)	162 (4,3)	162 (4,3)	
350 (24,2)	188 (5,0)	188 (5,0)	188 (5,0)	188 (5,0)	188 (5,0)	188 (5,0)	188 (5,0)	188 (5,0)	188 (5,0)	188 (5,0)	188 (5,0)	188 (5,0)	188 (5,0)	
400 (27,6)	215 (5,8)	215 (5,8)	215 (5,8)	215 (5,8)	215 (5,8)	215 (5,8)	215 (5,8)	215 (5,8)	215 (5,8)	215 (5,8)	215 (5,8)	215 (5,8)	215 (5,8)	
1-1/8 (28,6)	1(0,069)	5 (0,1) ⁽²⁾		6 (0,2) ⁽²⁾										
	2 (0,14)	7.5 (0,2) ⁽²⁾	7.5 (0,2) ⁽²⁾	8.5 (0,2) ⁽²⁾										
	3 (0,21)	9 (0,2)		10 (0,3)	8.5 (0,2) ⁽²⁾									
	4 (0,28)	10 (0,3)	10 (0,3)	10 (0,3)	8.5 (0,2) ⁽²⁾									
	5 (0,34)	12 (0,3)	12 (0,3)	12 (0,3)	10 (0,3)	9 (0,2) ⁽²⁾								
	6 (0,41)	13 (0,4)	13 (0,4)	13 (0,4)	12 (0,3)	10 (0,3)	9 (0,2) ⁽²⁾							
	7 (0,48)	15 (0,4)	14 (0,4)	14 (0,4)	13 (0,4)	12 (0,3)	10 (0,3)	9 (0,2) ⁽²⁾						
	8 (0,55)	16 (0,4)	16 (0,4)	15 (0,4)	14 (0,4)	13 (0,4)	12 (0,3)	11 (0,3)	9 (0,2) ⁽²⁾					
	9 (0,62)	17 (0,5)	17 (0,5)	17 (0,5)	16 (0,4)	15 (0,4)	14 (0,4)	12 (0,3)	11 (0,3)	10 (0,3) ⁽²⁾				
	10 (0,69)	19 (0,5)	19 (0,5)	19 (0,5)	17 (0,5)	16 (0,4)	15 (0,4)	14 (0,4)	13 (0,4)	12 (0,3)	10 (0,3) ⁽²⁾			
	15 (1,0)	24 (0,6)	24 (0,6)	24 (0,6)	24 (0,6)	24 (0,6)	23 (0,6)	22 (0,6)	22 (0,6)	20 (0,5)	20 (0,5)	19 (0,5)	13 (0,4)	
	20 (1,4)	31 (0,8)	31 (0,8)	31 (0,8)	31 (0,8)	31 (0,8)	31 (0,8)	31 (0,8)	30 (0,8)	30 (0,8)	27 (0,7)	26 (0,7)	25 (0,7)	24 (0,6)
	25 (1,7)	35 (0,9)	35 (0,9)	35 (0,9)	35 (0,9)	35 (0,9)	35 (0,9)	35 (0,9)	35 (0,9)	35 (0,9)	35 (0,9)	33 (0,9)	33 (0,9)	32 (0,9)
	30 (2,1)	39 (1,1)	39 (1,1)	39 (1,1)	39 (1,1)	39 (1,1)	39 (1,1)	39 (1,1)	39 (1,1)	39 (1,1)	39 (1,1)	39 (1,1)	39 (1,1)	39 (1,1)
	35 (2,4)	44 (1,2)	44 (1,2)	44 (1,2)	44 (1,2)	44 (1,2)	44 (1,2)	44 (1,2)	44 (1,2)	44 (1,2)	44 (1,2)	44 (1,2)	44 (1,2)	44 (1,2)
	40 (2,8)	47 (1,3)	47 (1,3)	47 (1,3)	47 (1,3)	47 (1,3)	47 (1,3)	47 (1,3)	47 (1,3)	47 (1,3)	47 (1,3)	47 (1,3)	47 (1,3)	47 (1,3)
	50 (3,4)	57 (1,5)	57 (1,5)	57 (1,5)	57 (1,5)	57 (1,5)	57 (1,5)	57 (1,5)	57 (1,5)	57 (1,5)	57 (1,5)	57 (1,5)	57 (1,5)	57 (1,5)
	60 (4,1)	65 (1,7)	65 (1,7)	65 (1,7)	65 (1,7)	65 (1,7)	65 (1,7)	65 (1,7)	65 (1,7)	65 (1,7)	65 (1,7)	65 (1,7)	65 (1,7)	65 (1,7)
	75 (5,2)	78 (2,1)	78 (2,1)	78 (2,1)	78 (2,1)	78 (2,1)	78 (2,1)	78 (2,1)	78 (2,1)	78 (2,1)	78 (2,1)	78 (2,1)	78 (2,1)	78 (2,1)
	100 (6,9)	99 (2,7)	99 (2,7)	99 (2,7)	99 (2,7)	99 (2,7)	99 (2,7)	99 (2,7)	99 (2,7)	99 (2,7)	99 (2,7)	99 (2,7)	99 (2,7)	99 (2,7)
125 (8,6)	122 (3,3)	122 (3,3)	122 (3,3)	122 (3,3)	122 (3,3)	122 (3,3)	122 (3,3)	122 (3,3)	122 (3,3)	122 (3,3)	122 (3,3)	122 (3,3)	122 (3,3)	
150 (10,3)	143 (3,8)	143 (3,8)	143 (3,8)	143 (3,8)	143 (3,8)	143 (3,8)	143 (3,8)	143 (3,8)	143 (3,8)	143 (3,8)	143 (3,8)	143 (3,8)	143 (3,8)	
175 (12,0)	160 (4,3)	160 (4,3)	160 (4,3)	160 (4,3)	160 (4,3)	160 (4,3)	160 (4,3)	160 (4,3)	160 (4,3)	160 (4,3)	160 (4,3)	160 (4,3)	160 (4,3)	
200 (13,8)	180 (4,8)	180 (4,8)	180 (4,8)	180 (4,8)	180 (4,8)	180 (4,8)	180 (4,8)	180 (4,8)	180 (4,8)	180 (4,8)	180 (4,8)	180 (4,8)	180 (4,8)	
225 (16,0)	205 (5,5)	205 (5,5)	205 (5,5)	205 (5,5)	205 (5,5)	205 (5,5)	205 (5,5)	205 (5,5)	205 (5,5)	205 (5,5)	205 (5,5)	205 (5,5)	205 (5,5)	
250 (17,2)	220 (5,9)	220 (5,9)	220 (5,9)	220 (5,9)	220 (5,9)	220 (5,9)	220 (5,9)	220 (5,9)	220 (5,9)	220 (5,9)	220 (5,9)	220 (5,9)	220 (5,9)	
300 (20,7)	265 (7,1)	265 (7,1)	265 (7,1)	265 (7,1)	265 (7,1)	265 (7,1)	265 (7,1)	265 (7,1)	265 (7,1)	265 (7,1)	265 (7,1)	265 (7,1)	265 (7,1)	
Type 61L Pilot														

1. When sizing a regulator, always use the lowest inlet pressure, the highest outlet pressure, and the maximum capacity desired.
 2. Requires 3/4 psig (0.052 bar) minimum differential pressure construction.

Table 6. Capacities⁽¹⁾ in Thousands of SCFH (m³/h(n)) of 0.6 Specific Gravity Gas⁽²⁾ for Full-Capacity Type 99 Regulators (continued)

SEAT RING SIZE, INCHES (mm)	INLET PRESSURE, PSIG (bar)	CAPACITIES ⁽¹⁾ IN THOUSANDS OF SCFH (m ³ /h(n)) OF 0.6 SPECIFIC GRAVITY NATURAL GAS																						
		Outlet Pressure, psig (bar)																						
		15 (1,0)	20 (1,4)	25	30 (2,1)	35	40 (2,8)	45	50	60 (4,1)	75	100 (6,9)												
7/8 (22,2)	5 (0,34) 6 (0,41) 7 (0,48) 8 (0,55) 9 (0,62)																							
	10 (0,69) 15 (1,0) 20 (1,4) 25 (1,7) 30 (2,1)	10.8 (0,3) 16.2 (0,4) 20 (0,5)	12 (0,3) 17 (0,5)	12.5 (0,3)																				
	35 (2,4) 40 (2,8) 50 (3,4) 60 (4,1) 75 (5,2)	24 (0,6) 28 (0,8) 34 (0,9) 42 (1,1) 47 (1,3)	21 (0,6) 26 (0,7) 34 (0,9) 42 (1,1) 47 (1,3)	18 (0,5) 23 (0,6) 31 (0,8) 42 (1,1) 47 (1,3)	13 (0,4) 19 (0,5) 28 (0,8) 37 (1,0) 47 (1,3)	14.4 (0,4) 25 (0,7) 35 (0,9) 45 (1,2)	21 (0,6) 30 (0,8) 41 (1,1)	15.5 (0,4) 27 (0,7) 37 (1,0)	23 (0,6) 30 (0,8)															
	100 (6,9) 125 (8,6) 150 (10,3) 175 (12,0) 200 (13,8)	59 (1,6) 73 (2,0) 86 (2,3) 96 (2,6) 108 (2,9)	59 (1,6) 73 (2,0) 86 (2,3) 96 (2,6) 108 (2,9)	59 (1,6) 73 (2,0) 86 (2,3) 96 (2,6) 108 (2,9)	59 (1,6) 73 (2,0) 86 (2,3) 96 (2,6) 108 (2,9)	59 (1,6) 73 (2,0) 86 (2,3) 96 (2,6) 108 (2,9)	59 (1,6) 73 (2,0) 86 (2,3) 96 (2,6) 108 (2,9)	59 (1,6) 73 (2,0) 86 (2,3) 96 (2,6) 108 (2,9)	59 (1,6) 73 (2,0) 86 (2,3) 96 (2,6) 108 (2,9)	59 (1,6) 73 (2,0) 86 (2,3) 96 (2,6) 108 (2,9)	53 (1,4) 73 (2,0) 86 (2,3) 96 (2,6) 108 (2,9)	44 (1,2) 66 (1,8) 86 (2,3) 96 (2,6) 108 (2,9)	48 (1,3) 72 (1,9) 93 (2,5) 108 (2,9)											
	225 (16,0) 250 (17,2) 300 (20,7) 350 (24,2) 400 (27,6)	123 (3,3) 132 (3,5) 162 (4,3) 188 (5,0) 215 (5,8)	123 (3,3) 132 (3,5) 162 (4,3) 188 (5,0) 215 (5,8)	123 (3,3) 132 (3,5) 162 (4,3) 188 (5,0) 215 (5,8)	123 (3,3) 132 (3,5) 162 (4,3) 188 (5,0) 215 (5,8)	123 (3,3) 132 (3,5) 162 (4,3) 188 (5,0) 215 (5,8)	123 (3,3) 132 (3,5) 162 (4,3) 188 (5,0) 215 (5,8)	123 (3,3) 132 (3,5) 162 (4,3) 188 (5,0) 215 (5,8)	123 (3,3) 132 (3,5) 162 (4,3) 188 (5,0) 215 (5,8)	123 (3,3) 132 (3,5) 162 (4,3) 188 (5,0) 215 (5,8)	123 (3,3) 132 (3,5) 162 (4,3) 188 (5,0) 215 (5,8)	123 (3,3) 132 (3,5) 162 (4,3) 188 (5,0) 215 (5,8)	123 (3,3) 132 (3,5) 162 (4,3) 188 (5,0) 215 (5,8)											
	1-1/8 (28,6)	1(0,069) 2 (0,14) 3 (0,21) 4 (0,28) 5 (0,34)																						
		6 (0,41) 7 (0,48) 8 (0,55) 9 (0,62) 10 (0,69)																						
		15 (1,0) 20 (1,4) 25 (1,7) 30 (2,1) 35 (2,4)	18 (0,5) 27 (0,7) 34 (0,9) 40 (1,1)	20 (0,5) 28 (0,8) 35 (0,9)	21 (0,6) 30 (0,8)	22 (0,6)																		
		40 (2,8) 50 (3,4) 60 (4,1) 75 (5,2)	47 (1,3) 57 (1,5) 65 (1,7) 78 (2,1)	43 (1,2) 57 (1,5) 65 (1,7) 78 (2,1)	38 (1,0) 52 (1,4) 65 (1,7) 78 (2,1)	32 (0,9) 47 (1,3) 62 (1,7) 78 (2,1)	24 (0,6) 42 (1,1) 58 (1,6) 74 (2,0)	35 (0,9) 50 (1,3) 68 (1,8)	26 (0,7) 45 (1,2) 68 (1,8)	38 (1,0) 50 (1,3)														
		100 (6,9) 125 (8,6) 150 (10,3) 175 (12,0)	99 (2,7) 122 (3,3) 143 (3,8) 160 (4,3)	99 (2,7) 122 (3,3) 143 (3,8) 160 (4,3)	99 (2,7) 122 (3,3) 143 (3,8) 160 (4,3)	99 (2,7) 122 (3,3) 143 (3,8) 160 (4,3)	99 (2,7) 122 (3,3) 143 (3,8) 160 (4,3)	99 (2,7) 122 (3,3) 143 (3,8) 160 (4,3)	99 (2,7) 122 (3,3) 143 (3,8) 160 (4,3)	99 (2,7) 122 (3,3) 143 (3,8) 160 (4,3)	99 (2,7) 122 (3,3) 143 (3,8) 160 (4,3)	99 (2,7) 122 (3,3) 143 (3,8) 160 (4,3)	88 (2,4) 122 (3,3) 143 (3,8) 160 (4,3)	80 (2,1) 120 (3,2) 155 (4,2)										
		200 (13,8) 225 (16,0) 250 (17,2) 300 (20,7)	180 (4,8) 205 (5,5) 220 (5,9) 265 (7,1)	180 (4,8) 205 (5,5) 220 (5,9) 265 (7,1)	180 (4,8) 205 (5,5) 220 (5,9) 265 (7,1)	180 (4,8) 205 (5,5) 220 (5,9) 265 (7,1)	180 (4,8) 205 (5,5) 220 (5,9) 265 (7,1)	180 (4,8) 205 (5,5) 220 (5,9) 265 (7,1)	180 (4,8) 205 (5,5) 220 (5,9) 265 (7,1)	180 (4,8) 205 (5,5) 220 (5,9) 265 (7,1)	180 (4,8) 205 (5,5) 220 (5,9) 265 (7,1)	180 (4,8) 205 (5,5) 220 (5,9) 265 (7,1)	180 (4,8) 205 (5,5) 220 (5,9) 265 (7,1)	180 (4,8) 205 (5,5) 220 (5,9) 265 (7,1)										
		Type 61L Pilot		Type 61H Pilot				Type 61HP Pilot																

1. When sizing a regulator, always use the lowest inlet pressure, the highest outlet pressure, and the maximum capacity desired.
 2. Requires 3/4 psig (0.052 bar) minimum differential pressure construction.

Ordering Information

Review the Specifications section (page 4) and Construction Features section (page 7–11). Complete the Ordering Guide. Also, please complete the Specifications Worksheet at the bottom of this page.

Ordering Guide

Body Material and End Connection Style (Select One)

Cast Iron Body

- NPT Screwed***
- 125B FF***
- 250B RF***

WCB Steel Body

- NPT Screwed***
- 150 RF**
- 300 RF**
- SWE*

Port Diameter (Select One)

- 3/8-inch (9,5 mm)***
- 1/2-inch (12,7 mm)***
- 9/16-inch (14,3 mm)***
- 5/8-inch (15,9 mm)**
- 3/4-inch (19,1 mm)***
- 7/8-inch (22,2 mm)***
- 1-inch (25,4 mm)**
- 1-1/8-inch (28,6 mm)***
- 7/8 x 3/8-inch (22 x 9,5 mm)**
- 7/8 x 1/2-inch (22,2 x 12,7 mm)**
- 7/8 x 5/8-inch (22,2 x 15,9 mm)**

Trim Material Main Valve and Pilot (Select One)

- Brass with disk seat (standard)***
- Stainless steel with disk seat**
- Brass with O-ring seat (7/8 and 1-1/8-inch port)***
- Stainless steel with O-ring seat (7/8 and 1-1/8-inch port)**

Seat Material (See Table 3) (Select One)

- Nitrile***
- Neoprene**
- Nylon**

* * *	Standard - Readily Available for Shipment
* *	Non-Standard - Allow Additional Time for Shipment
*	Special Order, Constructed from Non-Stocked Parts. Consult Your Fisher Sales Representative for Availability.
Availability of the product being ordered is determined by the component with the longest shipping time for the requested construction.	

Main Valve Spring (See Table 3) (Select One)

Maximum Allowable Drop and Spring Part Number

- 25 psig (1,7 bar) 1C277127022***
- 50 psig (3,4 bar) 1N801927022***
- 250 psig (17,2 bar) 1B883327022***
- 1000 psig (69 bar) 0W019127022**

Tubing and Fittings (Select One)

- Copper tubing and brass fittings (standard)***
- Stainless steel tubing and stainless steel fittings**

Outlet Pressure Ranges (See Table 1) (Select One)

- 2 to 4-inches w.c. (5 to 10 mbar)*
- 3 to 12-inches w.c. (7 to 30 mbar)***
- 0.25 to 2 psig (17 to 138 mbar)***
- 1 to 5 psig (0,069 to 0,34 bar)***
- 2 to 10 psig (0,14 to 0,69 bar)**
- 5 to 15 psig (0,34 to 1,0 bar)***
- 10 to 20 psig (0,69 to 1,4 bar)**
- 10 to 65 psig (0,69 to 4,5 bar)***
- 35 to 100 psig (2,4 to 6,9 bar)***

Monitor O-Ring Stem Seal (Optional)

- Yes

Main Valve Parts Kit (Optional)

- Yes, please send me one parts kit to match this order.

Pilot Parts Kit (Optional)

- Yes, please send me one parts kit to match this order.

Specification Worksheet

Application:

Specific Use _____

Line Size _____

Gas Type and Specific Gravity _____

Gas Temperature _____

Does the Application Require Overpressure Protection?

Yes No If yes, which is preferred:

Relief Valve Monitor Regulator Shutoff Device

Is overpressure protection equipment selection assistance desired? _____

Pressure:

Maximum Inlet Pressure (P_{1max}) _____

Minimum Inlet Pressure (P_{1min}) _____

Downstream Pressure Setting(s) (P_2) _____

Maximum Flow (Q_{max}) _____

Performance Required:

Accuracy Requirements? _____

Need for Extremely Fast Response? _____

Other Requirements: _____

©Fisher Controls International, Inc., 1979, 2001; All Rights Reserved

Fisher and Fisher Regulators are marks owned by Fisher Controls International, Inc. The Emerson logo is a trade mark and service mark of Emerson Electric Co. All other marks are the property of their respective owners.

The contents of this publication are presented for informational purposes only, and while every effort has been made to ensure their accuracy, they are not to be construed as warranties or guarantees, express or implied, regarding the products or services described herein or their use or applicability. We reserve the right to modify or improve the designs or specifications of such products at any time without notice.

For information, contact Fisher Controls:

Marshalltown, Iowa 50158 USA

28320 Gallardon, France

Sao Paulo 05424 Brazil

Singapore 128461

Printed in U.S.A.

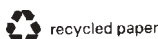

www.FISHERregulators.com

