

Excess Flow Valves for Flange Mounting in Container Service A3500 Series and A4500 Series

Application

Designed for mounting in flanged tank connections with internal threads in the bottom of a container. They may be used in filling, withdrawal or vapor equalizing application. They provide high flow capacity with low pressure drop to minimize pump inlet line cavitation.

If a riser pipe to the vapor space is used with these excess flow valves, the minimum inside diameter of the riser pipe must be at least two times the valve thread size in order not to restrict flow to the side inlet ports.

Flange mounted excess flow valves are readily accessible for servicing and completely enclosed and protected in event of fire. Because there is no direct connection between external piping and the valve, stresses imposed on piping will not affect the excess flow valve.

Features

- Precision machined.
- Generous flow channels provide low pressure drop minimizing cavitation in pump suction lines.
- Cotter pin prevents loss of spring retainer due to vibration in service.
- Stainless steel spring provides consistent closing flow and long service life.

Materials

Body Cadmium Plated Steel
 Seat Disc Cadmium Plated Steel
 Stem Stainless Steel
 Spring Stainless Steel
 Guide Cadmium Plated Steel

Flanged Installation In Container

NOTE: The opening in the tank flange should be machined with a ¼"-45° chamfer at the outer edge. The thread should be tapped one or two turns large as checked by a plug gauge. This and the undersize thread on the valve should permit the valve to be installed so that its outer face is at least flush with the outer edge of the flange.

The valve is screwed into this opening by fitting a ¼" flat metal piece into the slot and turning until hand tight. A lubricant may be used, but a luting compound is not necessary since this joint does not have to be gas tight.

If any difficulty is experienced in "making up" the valve to fit flush, as indicated, the thread in the tank flange can be tapped.

Design and construction of tank and flange must be in accordance with the appropriate section of the ASME Pressure Vessel Code.

Ordering Information

Part Number	A Inlet Connection NPT	B For Installation	C Effective Thread (Approx.)	D Threaded End To Port	Approximate Closing Flows*			
					Liquid (GPM Propane)	Vapor SCFH (Propane)		
						25 PSIG Inlet	100 PSIG Inlet	
A3500L4	2"	Slotted Body	¾"	1 1/16"	75	13,000	22,500	
A3500N4					125	25,000	42,500	
A3500P4					150	30,500	52,000	
A3500R6			3"	1"	1 1/8"	150	32,100	55,500
A3500T6						200	39,400	68,300
A3500V6						250	51,100	88,700
A4500Y8	4"		1 1/8"	1 1/8"	500	89,000	154,000	

NOTE: Multiply flow rate by .94 to determine liquid butane flow and by .90 to determine liquid anhydrous ammonia flow.

* Based on horizontal installation of excess flow valve. Flows are slightly more when valves are installed with outlet up; slightly less when installed with outlet down.

F14

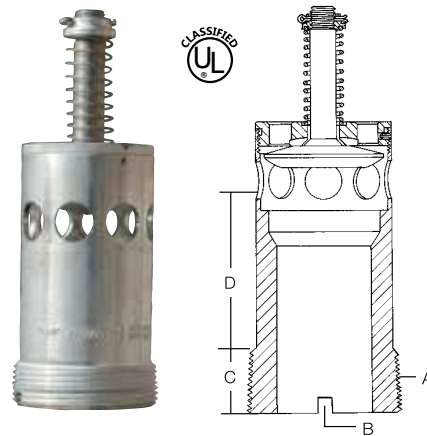

Performance

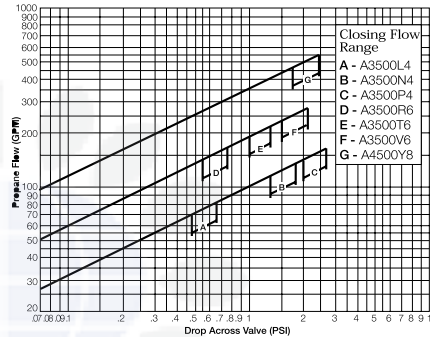

Specifications for companion flanges, gaskets, bolts and nuts must meet the appropriate codes, such as ASA B16.5.

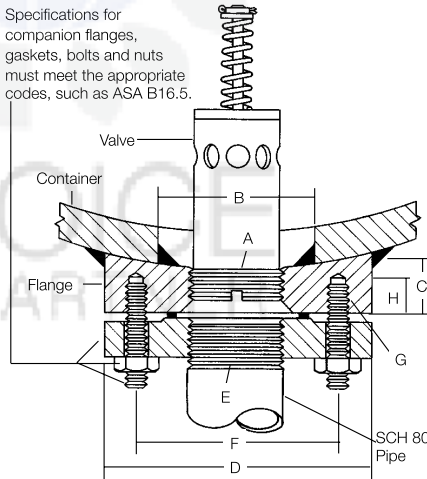

Key No.	Description	A3400L4, A3500L4, A3500N4, A3500P4	A3400L6, A3500R6, A3500T6, A3500V6	A4500Y8
A	Valve Size (NPT)	2"	3"	4"
B	Tank Opening	3 1/2"	4 1/2"	5 1/2"
C	Thickness (min.)	1"	1 1/4"	1 3/8"
D	Outside Diameter	6 1/2"	8 1/4"	10"
E	Pipe Thread (NPT)	2"	3"	4"
F	Bolt Circle Dia.	5"	6 1/2"	7 1/8"
	Number of Bolt Holes	8	8	8
G	Bolt Hole Thread	5/8" -11 NC - 2	3/4" - 10 NC - 2	3/4" - 10 NC - 2
H	Bolt Hole Thread (min. eff.)	3/4"	1"	1 1/8"