

# Semi-Internal "Pop-Action" Pressure Relief Valves for ASME Containers 7583, 8684 and 8685 Series

## Application

Designed for use as a primary relief valve on ASME containers such as 250, 500 and 1,000 gallon tanks. Underwriters' Laboratories lists containers systems on which these types of valves are mounted outside the hood without additional protection, if mounted near the hood and fitted with a protective cap.

## Features

- Constructed of non-corrosive materials.
- "Pop-action" design keeps product loss at a minimum.
- ASME rated for use with LP-Gas.
- Request RegO® Relief Valves on all your original equipment ASME containers for reliable performance.

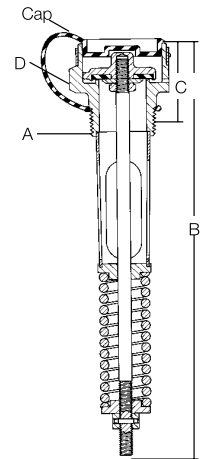

## Materials

Body ..... Brass  
 Spring ..... Steel  
 Stem ..... Stainless Steel  
 Seat Disc ..... Resilient Rubber

## Ordering Information

| Part Number | Start To Discharge Setting PSIG | A<br>Container Connection<br>M. NPT | B<br>Overall Height<br>(Approx.) | C<br>Height Above<br>Coupling<br>(Approx.) | D<br>Wrench<br>Hex<br>Section | Flow Capacity SCFM/Air       |                                | Suitable for<br>Tanks w/Surface<br>Area Up To:* | Protective<br>Cap (Included) |
|-------------|---------------------------------|-------------------------------------|----------------------------------|--|-------------------------------|------------------------------|--------------------------------|---|------------------------------|
|             |                                 |                                     |                                  |  |                               | UL (At 120% of Set Pressure) | ASME (At 120% of Set Pressure) |   |                              |
| 7583G       | 250                             | 3/4"                                | 8 3/8"                           | 1 1/8"                                     | 1 1/4"                        | 1980                         | 1806                           | 80 Sq. Ft.                                      | 7583-40X                     |
| 8684G       |                                 | 1"                                  | 9 3/8"                           | 1 1/8"                                     | 1 1/8"                        | 2620                         | 2565                           | 113 Sq. Ft.                                     | 8684-40                      |
| 8685G       |                                 | 1 1/4"                              | 11 1/8"                          | 1 1/8"                                     | 2 3/8"                        | 4385                         | 4035                           | 212 Sq. Ft.                                     | 7585-40X                     |

\* Per NFPA Pamphlet #58, Appendix D. Area shown is for UL or ASME flow rating—whichever is larger.

## Application

Designed especially for use as a primary relief valve on large stationary storage containers, these low profile relief valves are generally mounted in half couplings. However, they are designed so that the inlet ports clear the bottom of a full 2" coupling. This assures that the relief valve should always be capable of maximum flow under emergency conditions.

## Features

- High capacity, low turbulence design has a maximum guiding area providing for dependable shut-off after opening.
- Built-in spring stop limits the rise of the seat in full open position and prevents the spring from going "solid".
- External 3" NPT threaded body allows easy attachment of vent stacks. Optional pipeaway adapter has break-off groove to prevent damage to the relief valve should piping be stressed by damaging winds.
- "Pop-Action" design keeps product loss at a minimum.
- No guiding projections around the seat disc retainer to bind and hinder opening of valve if body is damaged.

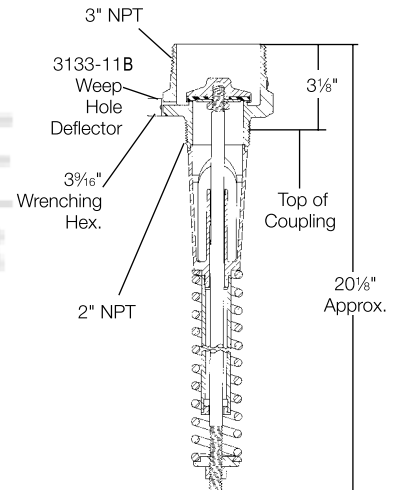

## Materials

Body ..... Brass  
 Spring ..... Steel  
 Stem ..... Stainless Steel  
 Seat Disc ..... Resilient Rubber

## Ordering Information

| Part Number | Start To Discharge Setting PSIG | Container Connection M. NPT | Flow Capacity SCFM/Air*      |                                |   | Accessories    |                  |
|-------------|---------------------------------|-----------------------------|------------------------------|--------------------------------|---|----------------|------------------|
|             |                                 |                             | UL (At 120% of Set Pressure) | ASME (At 120% of Set Pressure) | Suitable for Tanks w/ Surface Area Up To:** | Protective Cap | Pipeaway Adapter |
| 7534B       | 125                             | 2"                          | 6,025                        | -                              | 319 Sq. Ft.                                 | 7534-40        | 7534-20***       |
| 7534G       | 250                             |                             | 11,675                       | 10,422                         | 708 Sq. Ft.                                 |                |                  |

\* Flow rates shown are for bare relief valves. Adapters and pipeaways will reduce flow as discussed in the forewording information.

\*\* Per NFPA Pamphlet #58, Appendix D. Area shown is for UL or ASME—whichever is larger.

\*\*\* 3" F. NPT outlet connection.